

Physics 111 Final Exam, Spring 2013, Version A

Name (Print): _____ 4 Digit ID: _____ Section: _____

Honors Code Pledge: For ethical and fairness reasons all students are pledged to comply with the provisions of the NJIT Academic Honor Code. You must answer the exam questions entirely by yourself. **Turn off all cell phones, pagers, or other communication devices.** Use only your own calculator.

Instructions:

- First, write your name and section number on **both** the Scantron card and this exam sheet.
- Use the formula sheet (last exam booklet page) and no other materials.
- Budget your time. There are 25 multiple choice problems.
- Answer each question on the Scantron card using #2 pencil. Also circle your answers on question papers.
- Do not hesitate to ask for clarification of any exam question, if needed, from your proctor or Professor.

A

1. A student throws a set of keys vertically upward to her sorority sister, who is in a window 4.0m above. The second student catches the keys 1.50s later. With what initial speed were the keys thrown?

- A) 32 m/s
- B) 41m/s
- C) 10m/s**
- D) 22 m/s
- E) 82 m/s

2. Two blocks ($m_1 = 2\text{kg}$, $m_2 = 4\text{kg}$) are tied together by a string and pulled across a horizontal frictionless surface as shown in the figure. The external force which pulls m_2 has a magnitude of $F=10\text{N}$. Calculate the magnitude of the tension in the string between the two blocks.

- A) 10 N
- B) 1.7 N
- C) 6.7 N
- D) 3.3 N**
- E) none of the above

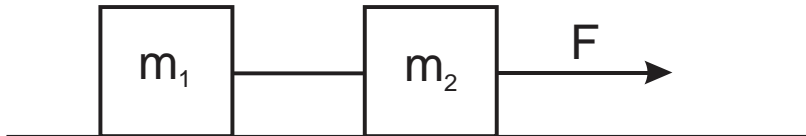

3. The position of a particle as a function of time is given by $\vec{r}(t) = 15t^2\hat{i} + 5t\hat{j} - 20t\hat{i} + 4t^4\hat{j}$. What is the magnitude of the acceleration at $t=0.5\text{s}$?

- A) 22 m/s²
- B) 42 m/s²
- C) 2 m/s
- D) 8.6 m/s
- E) none of the other answers**

4. An object moves with constant acceleration 4 m/s^2 and over a time interval reaches a final velocity of 12 m/s . If its initial velocity is -6m/s , what is its displacement during the time interval.

- A) none of the other answers
- B) 21 m
- C) 42.1 m
- D) 225 m
- E) 13.5 m**

5. Three forces (all in units of Newtons) acting on an object are given by $\vec{F}_1 = -2.0\hat{i} + 2.0\hat{j}$, $\vec{F}_2 = 5.0\hat{i} - 3.0\hat{j}$ and $\vec{F}_3 = -45.0\hat{i}$. The object experiences an acceleration of 3.75 m/s^2 . What is the mass of the object?

- A) 33.1 kg
- B) 20.4 kg
- C) 8.9 kg
- D) 11.2 kg**
- E) 68.4 kg

A

6. A block of mass 0.3 kg slides UP a frictionless plane having an inclination of $\theta = 25^\circ$. The block initially moves with a speed of 4 m/s . Find the magnitude of the acceleration of the block.

- A) 8.9 m/s^2
- B) 2.9 m/s^2
- C) none of the other answers
- D) 0 m/s^2
- E) 4.1 m/s^2**

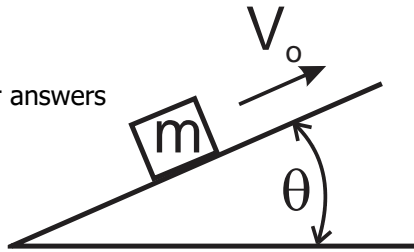

7. In the figure shown, the coefficient of kinetic friction between the block and the incline is 0.40 . What is the magnitude of the acceleration of the suspended block as it falls? Disregard any pulley mass or friction in the pulley.

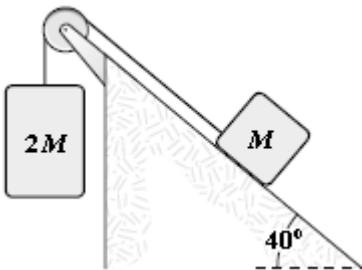

- a. 3.4 m/s^2**
- b. 3.7 m/s^2
- c. 4.2 m/s^2
- d. 3.9 m/s^2
- e. 5.4 m/s^2

8. A roller-coaster car has a mass of 500 kg when fully loaded with passengers. At the bottom of a circular dip of radius 40 m (as shown in the figure) the car has a speed of 16 m/s . What is the magnitude of the force of the track on the car at the bottom of the dip?

- a. 3.2 kN
- b. 8.1 kN**
- c. 4.9 kN
- d. 1.7 kN
- e. 5.3 kN

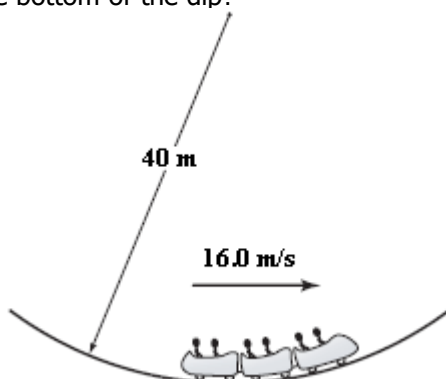

9. A pendulum is made by letting a 2.0-kg object swing at the end of a string that has a length of 1.5 m. The maximum angle the string makes with the vertical as the pendulum swings is 30° . What is the speed of the object at the lowest point in its trajectory?
- 2.0 m/s**
 - 2.2 m/s
 - 2.5 m/s
 - 2.7 m/s
 - 3.1 m/s

10. How much work is done by a person lifting a 2.0-kg object from the bottom of a well at a constant speed of 2.0 m/s for 5.0 s?
- 0.22 kJ
 - 0.20 kJ**
 - 0.24 kJ
 - 0.27 kJ
 - 0.31 kJ

A

11. A 1.5-kg block sliding on a rough horizontal surface is attached to one end of a horizontal spring ($k = 200 \text{ N/m}$) which has its other end fixed. If this system is displaced 20 cm horizontally from the equilibrium position and released from rest, the block first reaches the equilibrium position with a speed of 2.0 m/s. What is the coefficient of kinetic friction between the block and the horizontal surface on which it slides?
- 0.34**
 - 0.24
 - 0.13
 - 0.44
 - 0.17

12. If a 70-kg athlete were to bicycle to the summit of a 500-m high mountain while expending power at a constant rate of 746W, the amount of energy used by the athlete to cycle to the summit would be
- 746 J
 - $3.43 \times 10^5 \text{ J}$**
 - $3.73 \times 10^5 \text{ J}$
 - $7.46 \times 10^5 \text{ J}$
 - $2.61 \times 10^7 \text{ J}$

13. A car (mass 1000 kg) heading north runs a stop sign and collides with a truck (mass 3000 kg) which is heading East at a speed of 30m/s. After the collision, the car and truck are stuck together and move at an angle of 35 degrees relative to the East direction (see figure). What is the speed of the car BEFORE the collision.

- none of the other answers
- 14 m/s
- 21 m/s
- 90 m/s
- 63 m/s**

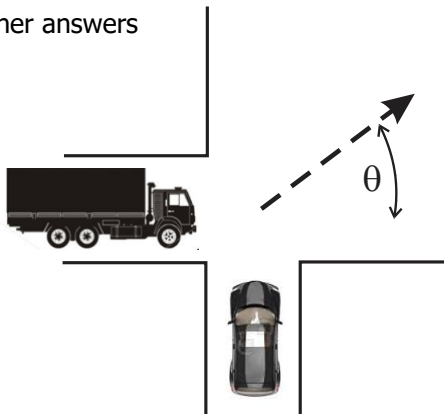

14. A multi-level pulley of rotational inertia $I = 0.1 \text{ kg}\cdot\text{m}^2$ is pivoted about a frictionless axis through O and perpendicular to the pulley, as shown in the figure (not to scale). If $a = 10 \text{ cm}$ and $b = 15 \text{ cm}$ (see the figure) what is the angular acceleration of the pulley ?

- A) **7.0 rad/s² clockwise**
- B) 7.0 rad/s² counterclockwise
- C) 2.0 rad/s² counterclockwise
- D) 2.0 rad/s² clockwise
- E) 0 rad/s² , equilibrium

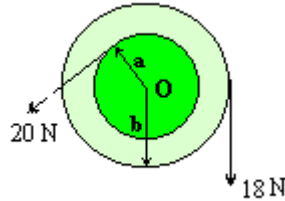

15. A meter stick is pivoted at one end and is allowed to swing freely starting from horizontal position. Find the angular velocity ω (in rad/s) when the meter stick is in the lowest vertical position.

- A) 7.7
- B) 15
- C) **5.4**
- D) 4.7
- E) 11

16. A fast 9-gram bullet gets stuck in a wooden block with mass $M=3 \text{ kg}$, initially at rest. After the impact, the block starts moving with velocity 1.5 m/s . Find the initial speed of the bullet.

- A) 250 m/s
- B) **500 m/s**
- C) 750 m/s
- D) 1000 m/s
- E) 1500 m/s

A

17. A solid ball is at the top of an incline of vertical height $H=10\text{m}$. It is released from rest and rolls without slipping. The mass of the ball is $M = 2 \text{ kg}$ and radius is $R = 0.2 \text{ m}$. Calculate the final speed of the ball at the bottom of the incline.

- A) **12 m/s**
- B) 11 m/s
- C) 9.9 m/s
- D) 14 m/s
- E) 22 m/s

18. Three identical objects of mass $M = 4\text{kg}$ are fastened to a massless rod of length $L = 1\text{m}$ as shown. The rotational inertia (in kg m^2) about one end of the rod of this array is:

- A) 1
- B) 2
- C) 3
- D) 4
- E) **5**

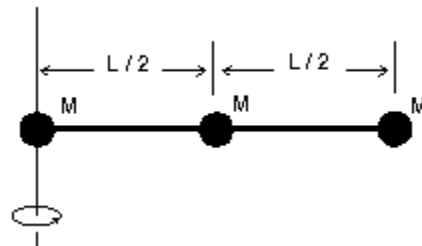

19. Two vectors lying in the xy plane are given by the equations $\vec{A} = 5\hat{i} + 2\hat{j}$ and $\vec{B} = 2\hat{i} - 3\hat{j}$. The value of $\vec{A} \times \vec{B}$ is
- $19\hat{k}$
 - $-11\hat{k}$
 - $-19\hat{k}$**
 - $11\hat{k}$
 - $10\hat{i} - \hat{j}$

20. In the figure, a 1.6-kg mass swings in a vertical circle at the end of a string having negligible weight. The string is 2 m long. If the mass is released with zero initial velocity from a horizontal position, its angular momentum (in $\text{kg}\cdot\text{m}^2/\text{s}$) at the lowest point of its path relative to the center of the circle is approximately

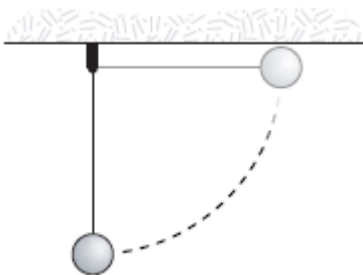

- 40
- 10
- 30
- 20**
- 50

A

21. A CD with rotational inertia of $2 \times 10^{-4} \text{ kg}\cdot\text{m}^2$ is freely spinning at 33 rev/min. A 5-gram chewing gum is dropped vertically onto the CD a distance of 7 cm from the axis of rotation. What is the new revolution frequency?

- 27 rev/min
- 29 rev/min**
- 31 rev/min
- 33 rev/min
- 35 rev/min

22. A safe whose mass is $M = 500 \text{ kg}$ is hanging by a rope from a massless bar whose length components are $a = 4 \text{ m}$ and $b = 5 \text{ m}$. The end of the bar near the wall is hinged and a horizontal (massless) cable attached to the wall holds up the other end. Find the tension in the horizontal cable.

- 333 N.
- 1634 N.
- 1837 N.
- 6125 N.**
- 4900 N.

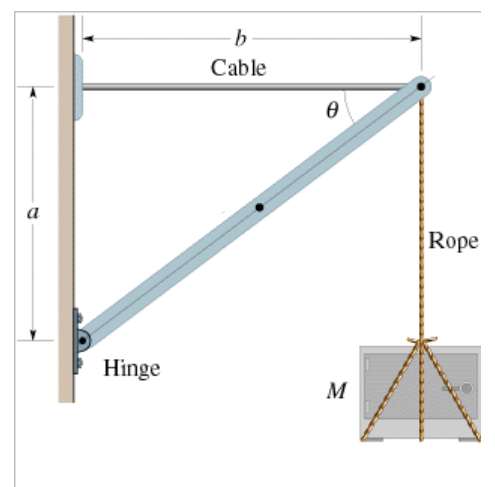

23. A uniform plank of length 2.0m and mass 30kg is supported by three ropes as indicated by the blue vectors in the figure. Find the tension T_3 when a 700N person is $d=0.5\text{m}$ from the left end.

- A) $T_1=236\text{ N}$
- B) $T_1=374\text{ N}$
- C) $T_1=501\text{ N}$**
- D) $T_1=38\text{ N}$
- E) $T_1=678\text{ N}$

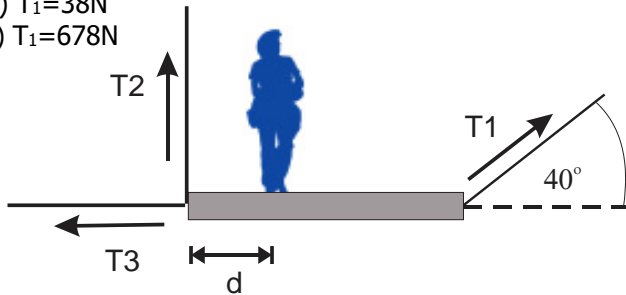

24. What is the magnitude of the free-fall acceleration at a point that is a distance $2R$ **above the surface** of the Earth, where R is the radius of the Earth?

- a. 4.8 m/s^2
- b. 1.1 m/s^2**
- c. 3.3 m/s^2
- d. 2.5 m/s^2
- e. 6.5 m/s^2

25. What is the escape speed from a planet of mass M and radius R if $M = 3.2 \times 10^{23}\text{ kg}$ and $R = 2.4 \times 10^6\text{ m}$ assuming that the object is initially at the planet's surface?

- a. 5.5 km/s
- b. 4.2 km/s**
- c. 5.2 km/s
- d. 4.8 km/s
- e. 3.7 km/s

A

FORMULAS – Final Exam

Conversion Factors: 1 inch = 2.54 cm; 1 mi = 1609.3 m; 1 cm = 10⁻² m; 1 mm = 10⁻³ m; 1 g = 10⁻³ kg;

Physical constants: $g = 9.8 \text{ m/s}^2$; $G = 6.674 \times 10^{-11} \text{ N m}^2/\text{kg}^2$; $M_{\text{Earth}} = 5.97 \times 10^{24} \text{ kg}$; $R_{\text{Earth}} = 6.37 \times 10^6 \text{ m}$

Math: $360^\circ = 2\pi \text{ radians} = 1 \text{ revolution}$. Arc length $s = r\theta$; $V_{\text{sphere}} = 4\pi R^3 / 3$; $A_{\text{sphere}} = 4\pi R^2$; $A_{\text{circle}} = \pi R^2$

quadratic formula to solve $ax^2 + bx + c = 0$: $x = \frac{-b \pm \sqrt{b^2 - 4ac}}{2a}$

Vectors: $\vec{A} = A_x \hat{i} + A_y \hat{j}$; $A_x = |\vec{A}| \cos(\theta)$; $A_y = |\vec{A}| \sin(\theta)$; $|\vec{A}| = \sqrt{A_x^2 + A_y^2}$; $\tan \theta = \frac{A_y}{A_x}$

$\vec{C} = \vec{A} + \vec{B}$ implies $C_x = A_x + B_x$; $C_y = A_y + B_y$

$\vec{A} \cdot \vec{B} = |\vec{A}| |\vec{B}| \cos \theta = A_x B_x + A_y B_y + A_z B_z$; $\hat{i} \cdot \hat{i} = 1 = \hat{j} \cdot \hat{j} = \hat{k} \cdot \hat{k}$; $\hat{i} \cdot \hat{j} = \hat{i} \cdot \hat{k} = \hat{j} \cdot \hat{k} = 0$

$|\vec{A} \times \vec{B}| = |\vec{A}| |\vec{B}| \sin \theta$; $\vec{A} \times \vec{B} = \hat{i}(A_y B_z - A_z B_y) + \hat{j}(A_z B_x - A_x B_z) + \hat{k}(A_x B_y - A_y B_x)$

$\hat{i} \times \hat{i} = \hat{j} \times \hat{j} = \hat{k} \times \hat{k} = 0$; $\hat{i} \times \hat{j} = \hat{k}$; $\hat{j} \times \hat{k} = \hat{i}$; $\hat{k} \times \hat{i} = \hat{j}$

1D and 2D motion:

$$v_{\text{avg}} = \frac{\Delta x}{\Delta t} \quad ; \quad a_{\text{avg}} = \frac{\Delta v}{\Delta t} \quad ; \quad v = \frac{dx}{dt} \quad ; \quad a = \frac{dv}{dt} = \frac{d^2 x}{dt^2}$$

$$\vec{v}_{\text{avg}} = \frac{\Delta \vec{r}}{\Delta t} \quad ; \quad \vec{a}_{\text{avg}} = \frac{\Delta \vec{v}}{\Delta t} \quad ; \quad \vec{v} = \frac{d\vec{x}}{dt} \quad ; \quad \vec{a} = \frac{d\vec{v}}{dt} = \frac{d^2 \vec{r}}{dt^2}$$

$$x = x_i + v_i t + \frac{1}{2} a t^2 \quad ; \quad v = v_i + a t \quad ; \quad v^2 = v_i^2 + 2a(x - x_i) \quad ; \quad \vec{r} = \vec{r}_i + \vec{v}_i t + \frac{1}{2} \vec{a} t^2 \quad ; \quad \vec{v} = \vec{v}_i + \vec{a} t$$

Circular motion: $T = 2\pi R / v$; $T = 2\pi / \omega$; $a_c = v^2 / R$

Newtons Laws: $\sum \vec{F} = m\vec{a}$; $\vec{F}_{12} = -\vec{F}_{21}$

Friction: $f_s \leq \mu_s N$; $f_k = \mu_k N$

Energies: $K = \frac{1}{2} m v^2$; $U_g = mgy$; $U_s = \frac{1}{2} k x^2$; $W = -\int \vec{F} \cdot d\vec{r} = -\vec{F} \cdot \Delta \vec{r}$

$E_{\text{total}} = K + U_g + U_s$; $\Delta E_{\text{mech}} = \Delta K + \Delta U_g + \Delta U_s = -f_s d$; $P = dW / dt = \vec{F} \cdot \vec{v}$; $\Delta K = W$

Momentum and Impulse: $\vec{p} = m\vec{v}$; $\vec{I} = \int \vec{F} dt = \Delta \vec{p}$

Center of mass: $\vec{r}_{\text{cm}} = \sum_i m_i \vec{r}_i / \sum_i m_i$; $\vec{v}_{\text{cm}} = \sum_i m_i \vec{v}_i / \sum_i m_i$

Collisions: $\vec{p} = \text{const}$ and $E \neq \text{const}$ (inelastic) or $\vec{p} = \text{const}$ and $E = \text{const}$ (elastic)

Rotational motion: $\omega = 2\pi / T$; $\omega = d\theta / dt$; $\alpha = d\omega / dt$; $v_t = r\omega$; $a_t = r\alpha$; $a_c = a_r = v_t^2 / r = \omega^2 r$

$a_{\text{tot}}^2 = a_r^2 + a_t^2$; $v_{\text{cm}} = r\omega$ (rolling, no slipping) ; $a_{\text{cm}} = r\alpha$

$\omega = \omega_o + \alpha t$; $\theta_f = \theta_i + \omega_o t + \alpha t^2 / 2$; $\omega_f^2 = \omega_i^2 + 2\alpha(\theta_f - \theta_i)$

$I_{\text{point}} = MR^2$; $I_{\text{hoop}} = MR^2$; $I_{\text{disk}} = MR^2 / 2$; $I_{\text{sphere}} = 2MR^2 / 5$; $I_{\text{shell}} = 2MR^2 / 3$; $I_{\text{rod}(center)} = ML^2 / 12$

$I_{\text{rod}(end)} = ML^2 / 3$; $I = \sum_i m_i r_i^2$; $I = I_{\text{cm}} + Mh^2$; $\vec{\tau} = \vec{r} \times \vec{F}$; $\sum \tau = I\alpha$; $\vec{L} = \vec{r} \times \vec{p}$; $\vec{L} = I\vec{\omega}$

Energy: $K_{\text{rot}} = I\omega^2 / 2$; $K = K_{\text{rot}} + K_{\text{cm}}$; $\Delta K + \Delta U = 0$; $W = \tau \Delta \theta$; $P_{\text{inst}} = \tau \omega$

Gravitation: $\vec{F}_g = -\frac{Gm_1 m_2}{r^2} \hat{r}_{12}$; $g(r) = GM / r^2$; $U = -Gm_1 m_2 / r$; $T^2 = \frac{4\pi^2}{GM} a^3$

Physics 111 Final Exam, Fall 2013, Version A

Name (Print): _____ 4 Digit ID: _____ Section: _____

Honors Code Pledge: For ethical and fairness reasons all students are pledged to comply with the provisions of the NJIT Academic Honor Code. You must answer the exam questions entirely by yourself. **Turn off all cell phones, pagers, or other communication devices.** Use only your own calculator.

Instructions:

- First, write your name and section number on **both** the Scantron card and this exam sheet.
- Use the formula sheet (last exam booklet page) and no other materials.
- Budget your time. There are 29 multiple choice problems.
- Answer each question on the Scantron card using #2 pencil. Also circle your answers on question papers.
- Do not hesitate to ask for clarification of any exam question, if needed, from your proctor or Professor.

A

1. A 1.2-kg object moving with a speed of 8.0 m/s collides perpendicularly with a wall and emerges with a speed of 6.0 m/s in the opposite direction. If the object is in contact with the wall for 2.0 ms, what is the magnitude of the average force on the object by the wall?

- A) 9.8 kN
- B) 8.4 kN**
- C) 7.7 kN
- D) 9.1 kN
- E) 1.2 kN

2. A 5.0-kg mass with an initial velocity of 4.0 m/s, east collides with a 4.0-kg mass with an initial velocity of 3.0 m/s, west. After the collision the 5.0-kg mass has a velocity of 1.2 m/s, south. What is the magnitude of the velocity of the 4.0-kg mass after the collision?

- A) 2.0 m/s
- B) 1.5 m/s
- C) 1.0 m/s
- D) 2.5 m/s**
- E) 3.0 m/s

3. A body oscillates with simple harmonic motion along the x axis. Its displacement varies with time according to the equation $x(t) = (5.0 \text{ m}) \sin [(\pi \text{ s}^{-1}) t + \pi/3]$. The velocity (in m/s) of the body at $t = 1.0 \text{ s}$ is

- A) +7.9
- B) -7.9**
- C) -14
- D) +14
- E) -5.0

4. The amplitude of a system moving with simple harmonic motion is doubled. The total energy will then be

- A) **4 times as large**
- B) 3 times as large
- C) 2 times as large
- D) the same as it was
- E) half as much

5. The mass in the figure slides on a frictionless surface. If $m = 2 \text{ kg}$, $k = 800 \text{ N/m}$, the frequency of oscillation (in Hz) is approximately



- A) 6.3
- B) 24.8
- C) **3.2**
- D) 17.1
- E) 10.9

6. The system in the figure is in equilibrium. A concrete block of mass 225 kg hangs from the end of the uniform strut whose mass is 46.0 kg. What is the magnitude of the tension T in the cable?

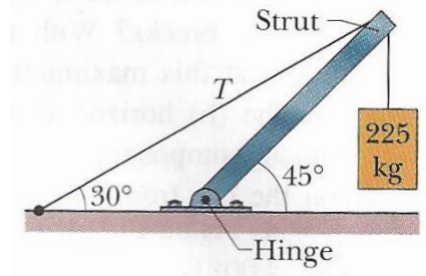

- A) 2.43 kN
- B) 3.44 kN
- C) 4.86 kN
- D) **6.64 kN**
- E) 7.26 kN

7. In the Problem 6, what is the magnitude of the force on the strut from the hinge?

- A) 2.43 kN
- B) 5.75 kN
- C) **8.29 kN**
- D) 8.83 kN
- E) 11.50 kN

8. An asteroid, headed directly toward Earth, has a speed of 12 km/s relative to the planet when it is at a distance of 10 Earth radii from Earth's center. Neglecting the effect of Earth's atmosphere on the asteroid, find the asteroid's speed when it reaches Earth's surface. The earth's radius and mass are $R_E = 6.38 \times 10^6 \text{ m}$ and $m_E = 5.97 \times 10^{24} \text{ kg}$.

- A) **16 km/s**
- B) 12 km/s
- C) 6 km/s
- D) 10 km/s
- E) 20 km/s

9. Three uniform spheres of masses $m_1 = 2.00 \text{ kg}$, $m_2 = 4.00 \text{ kg}$, and $m_3 = 6.00 \text{ kg}$ are placed at the corners of a right triangle as shown in the figure. Calculate the resultant gravitational force on the object of mass m_2 , assuming the spheres are isolated from the rest of the Universe.

- A) $5.93 \times 10^{-11} \text{ N}$
- B) $4.38 \times 10^{-10} \text{ N}$
- C) $1.00 \times 10^{-10} \text{ N}$
- D) $1.03 \times 10^{-10} \text{ N}$
- E) **$1.16 \times 10^{-10} \text{ N}$**

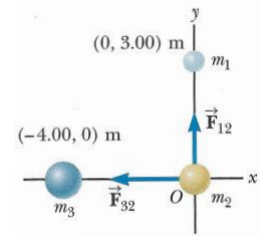

10. A planet moves in an elliptical orbit with the Sun at one focus. At what point does the planet move the fastest?

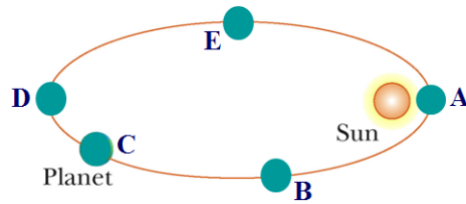

11. Three forces are acting on a mass of 2kg as shown in the figure. The magnitudes of the forces are $F_1=10 \text{ N}$, $F_2=5 \text{ N}$, and $F_3=7 \text{ N}$. What is the magnitude of the net acceleration of the mass?

- A) none of the other answers
- B) 4.5 m/s^2
- C) **1.5 m/s^2**
- D) 3.7 m/s^2
- E) 3.0 m/s^2

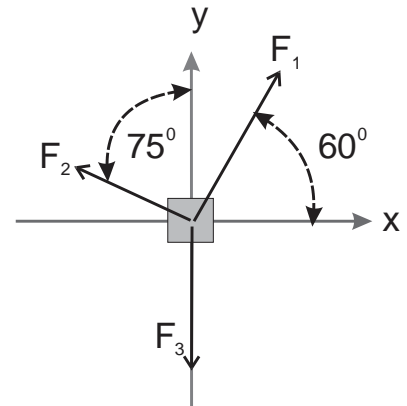

12. Two blocks ($m_1 = 2\text{kg}$, $m_2 = 3\text{kg}$) are pushed along a frictionless horizontal surface by an external force of magnitude $F=10\text{N}$. Calculate the magnitude of the force of m_1 on m_2 .

- A) 10 N
- B) 5 N
- C) 2 N
- D) 4 N
- E) **none of the above (6 N)**

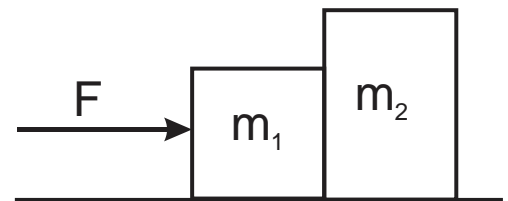

13. The mass in the figure is falling at CONSTANT speed. What is the coefficient of friction if $m_1=2$ kg, $m_2=1.8$ kg, and the angle of the incline is 40 degrees? The pulley is frictionless and massless.

- A) 0.2
- B) 0.54
- C) 2.3
- D) 0.61**
- E) none of the other answers

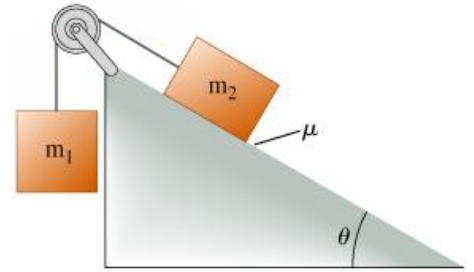

14. An object of mass 0.2kg is tied to a string 0.5 m long and swung in a vertical circle at constant velocity. If the speed of the mass is 3.0 m/s, what is the tension in the string when the mass is at the HIGHEST position in the vertical circle?

- A) 1.6 N**
- B) 2.0 N
- C) 5.6 N
- D) 3.6 N
- E) None of the other answers

15. At $t = 0$, a wheel rotating about a fixed axis at a constant angular acceleration has an angular velocity of 2.0 rad/s. Two seconds later it has turned through 5.0 complete revolutions. What is the angular acceleration of this wheel?

- A) 17 rad/s²
- B) 14 rad/s²**
- C) 20 rad/s²
- D) 23 rad/s²
- E) 13 rad/s²

16. In the figure below, a disk (radius $R = 1.0$ m, mass = 2.0 kg) is suspended from a pivot a distance $d = 0.25$ m above its center of mass. The moment of inertia (in kgm²) is approximately

- A) 0.125
- B) 0.250
- C) 0.425
- D) 0.750
- E) 1.125**

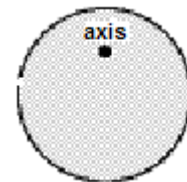

17. A frictionless pulley free to rotate about a frictionless axle has a radius $R = 0.12$ m and a moment of inertia $I = 0.050$ kg×m². A 1.5-kg object is attached to a very light wire that is wrapped around the rim of the pulley. The system is released from rest and mass m moves downward a distance of 63.7 cm. Find the angular velocity of the pulley at this instant.

- A) 28.4 rad/s
- B) 5.75 rad/s
- C) 16.2 rad/s**
- D) 0.25 rad/s
- E) 32.2 rad/s

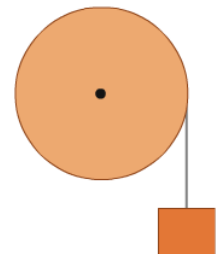

18. A thin rod of mass $M = 1.2$ kg and length $d = 2$ m is struck at one end by a ball of clay of mass $m = 0.050$ kg, moving with speed $v_0 = 7.5$ m/s as shown in the figure. The ball sticks to the rod. After the collision, the angular velocity of the clay-rod system about O, the midpoint of the rod, is

- A) 0.5 rad/s
- B) 1.1 rad/s
- C) 0.83 rad/s**
- D) 2.8 rad/s
- E) 4.0 rad/s

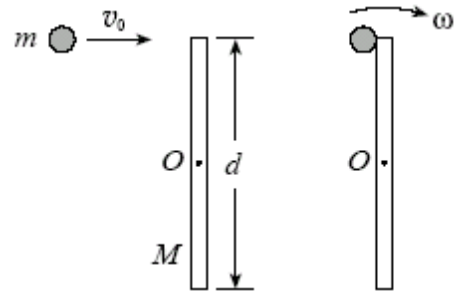

19. If $\vec{A} = 12\hat{i} - 16\hat{j}$ and $\vec{B} = -24\hat{i} + 10\hat{j}$, what is the magnitude of the vector $\vec{C} = \vec{A} \cdot \vec{B}$?

- A) 422
- B) 220
- C) 448**
- D) 903
- E) 135

20. A proton moving along the x axis has an initial speed in the positive x direction of $4.0 \cdot 10^6$ m/s and a constant acceleration in the positive x direction of $6.0 \cdot 10^{12}$ m/s². What is the velocity of the proton after it has traveled a distance of 80 cm?

- A) $5.1 \cdot 10^6$ m/s**
- B) $6.3 \cdot 10^6$ m/s
- C) $4.8 \cdot 10^6$ m/s
- D) $3.9 \cdot 10^6$ m/s
- E) $2.9 \cdot 10^6$ m/s

21. At $t = 0$, a particle leaves the origin with a velocity of 9.0 m/s in the positive y direction and moves in the xy plane with a constant acceleration of $(2.0\hat{i} + 4.0\hat{j})$ m/s². At the instant the x coordinate of the particle is 15 m, what is the speed of the particle?

- A) 16 m/s
- B) 25.7 m/s**
- C) 12 m/s
- D) 14 m/s
- E) 26 m/s

22. A car travels counterclockwise around a flat circle of radius 0.25 km at a constant speed of 20 m/s. When the car is at point A as shown in the figure, what is the car's acceleration?

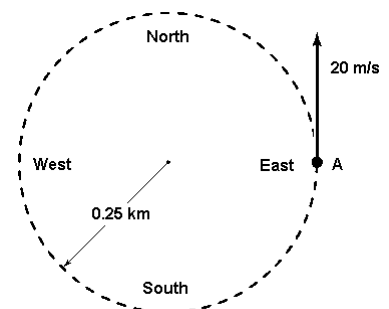

- A) 1.6 m/s², south

- B) Zero
- C) 1.6 m/s^2 , east
- D) 1.6 m/s^2 , north
- E) 1.6 m/s^2 , west**

23. In the figure, a 700-kg crate is on a rough surface inclined at 30° . A constant external force $P = 5600 \text{ N}$ is applied horizontally to the crate. As the force pushes the crate a distance of 3.00 m up the incline, the speed changes from 1.40 m/s to 2.50 m/s. How much work does gravity do on the crate during this process?

- A) -10,300 J**
- B) -3,400 J
- C) 10,300 J
- D) 3,400 J
- E) Zero

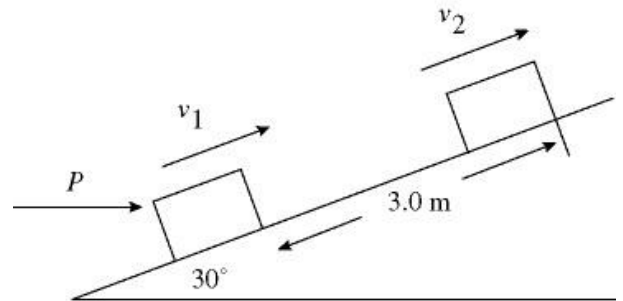

24. A child pulls on a wagon with a horizontal force of 75 N. If the wagon moves horizontally a total of 42 m in 3.0 min, what is the average power generated by the child?

- A) 18 W**
- B) 22 W
- C) 24 W
- D) 27 W
- E) Zero

25. A 20-N crate starting at rest slides down a rough 5.0-m long ramp, inclined at 25° with the horizontal. 20 J of energy is lost to friction. What will be the speed of the crate at the bottom of the incline?

- A) 0.98 m/s
- B) 1.9 m/s
- C) 3.2 m/s
- D) 4.7 m/s**
- E) 0.7 m/s

26. A simple pendulum, 1.00 m in length, is released from rest when the support string is at an angle of 35.0° from the vertical. What is the speed of the suspended mass at the bottom of the swing? ($g = 9.80 \text{ m/s}^2$ and ignore air resistance)

- A) 0.67 m/s
- B) 0.94 m/s
- C) 1.33 m/s
- D) 1.88 m/s**
- E) 1.55 m/s

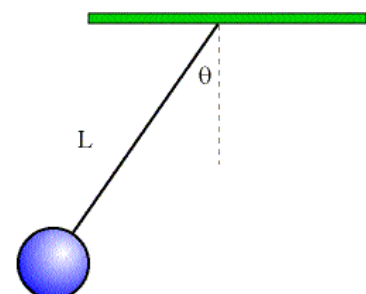

27. A hypodermic syringe contains water. The barrel of the syringe has a cross-sectional area $A=2.5 \times 10^{-5} \text{ m}^2$, and the needle has a cross-sectional area $a=1.00 \times 10^{-8} \text{ m}^2$. In the absence of a force on the plunger, the pressure everywhere is 1.00 atm. When a force \vec{F} of magnitude 2.00 N acts on the plunger, what is the speed of water as it leaves the needle.

- A) 25.27 m/s
- B) 12.65 m/s**
- C) 1.53 m/s
- D) 15.5 m/s
- E) 2.5 m/s

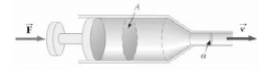

28. A solid rock, suspended in air by a spring scale, has a measured mass of 9.00 kg. When the rock is submerged in water, the scale reads 3.30 kg. What is the density of the rock? (water density = $1,000 \text{ kg/m}^3$).

- A) $4.55 \times 10^3 \text{ kg/m}^3$
- B) $3.50 \times 10^3 \text{ kg/m}^3$
- C) $1.20 \times 10^3 \text{ kg/m}^3$
- D) $1.58 \times 10^3 \text{ kg/m}^3$**
- E) $1.35 \times 10^3 \text{ kg/m}^3$

29. An ideal fluid flows through a pipe made of two sections with diameters of 1.0 and 3.0 inches, respectively. The speed of the fluid flow through the 3.0-inch section will be what factor times that through the 1.0-inch section?

- A) 6.0
- B) 9.0
- C) 1/3
- D) 1/9**
- E) 1/2

FORMULAS – Final Exam

Conversion Factors: 1 inch = 2.54 cm; 1 mi = 1609.3 m; 1 cm = 10^{-2} m; 1 mm = 10^{-3} m; 1 g = 10^{-3} kg;

Physical constants: $g = 9.8 \text{ m/s}^2$; $G = 6.674 \times 10^{-11} \text{ N m}^2/\text{kg}^2$; $M_{\text{Earth}} = 5.97 \times 10^{24} \text{ kg}$; $R_{\text{Earth}} = 6.37 \times 10^6 \text{ m}$

Math: $360^\circ = 2\pi \text{ radians} = 1 \text{ revolution}$. Arc length $s = r\theta$; $V_{\text{sphere}} = 4\pi R^3 / 3$; $A_{\text{sphere}} = 4\pi R^2$; $A_{\text{circle}} = \pi R^2$

quadratic formula to solve $ax^2 + bx + c = 0$: $x = \frac{-b \pm \sqrt{b^2 - 4ac}}{2a}$

Vectors: $\vec{A} = A_x \hat{i} + A_y \hat{j}$; $A_x = |\vec{A}| \cos(\theta)$; $A_y = |\vec{A}| \sin(\theta)$; $|\vec{A}| = \sqrt{A_x^2 + A_y^2}$; $\tan \theta = \frac{A_y}{A_x}$

$\vec{C} = \vec{A} + \vec{B}$ implies $C_x = A_x + B_x$; $C_y = A_y + B_y$

$\vec{A} \cdot \vec{B} = |\vec{A}| |\vec{B}| \cos(\theta) = A_x B_x + A_y B_y + A_z B_z$; $\hat{i} \cdot \hat{i} = \hat{j} \cdot \hat{j} = \hat{k} \cdot \hat{k} = 1$; $\hat{i} \cdot \hat{j} = \hat{i} \cdot \hat{k} = \hat{j} \cdot \hat{k} = 0$

$|\vec{A} \times \vec{B}| = |\vec{A}| |\vec{B}| \sin \theta$; $\vec{A} \times \vec{B} = \hat{i}(A_y B_z - A_z B_y) + \hat{j}(A_z B_x - A_x B_z) + \hat{k}(A_x B_y - A_y B_x)$

$\hat{i} \times \hat{i} = \hat{j} \times \hat{j} = \hat{k} \times \hat{k} = 0$; $\hat{i} \times \hat{j} = \hat{k}$; $\hat{j} \times \hat{k} = \hat{i}$; $\hat{k} \times \hat{i} = \hat{j}$

1D and 2D motion:

$\vec{v}_{\text{avg}} = \frac{\Delta \vec{r}}{\Delta t}$; $\vec{a}_{\text{avg}} = \frac{\Delta \vec{v}}{\Delta t}$; $\vec{v} = \frac{d\vec{x}}{dt}$; $\vec{a} = \frac{d\vec{v}}{dt} = \frac{d^2 \vec{r}}{dt^2}$

$x = x_i + v_i t + \frac{1}{2} a t^2$; $v = v_i + a t$; $v^2 = v_i^2 + 2a(x - x_i)$; $\vec{r} = \vec{r}_i + \vec{v}_i t + \frac{1}{2} \vec{a} t^2$; $\vec{v} = \vec{v}_i + \vec{a} t$

Circular motion: $T = 2\pi R / v$; $T = 2\pi / \omega$; $a_c = v^2 / R$

Newtons Laws: $\sum \vec{F} = m\vec{a}$; $\vec{F}_{12} = -\vec{F}_{21}$

Friction: $f_s \leq \mu_s N$; $f_k = \mu_k N$

Energies: $K = \frac{1}{2} m v^2$; $U_g = mgy$; $U_s = \frac{1}{2} k x^2$; $W = -\int \vec{F} \cdot d\vec{r} = -\vec{F} \cdot \Delta \vec{r}$

$E_{\text{total}} = K + U_g + U_s$; $\Delta E_{\text{mech}} = \Delta K + \Delta U_g + \Delta U_s = -f_s d$; $P = dW / dt = \vec{F} \cdot \vec{v}$; $\Delta K = W$

Momentum and Impulse: $\vec{p} = m\vec{v}$; $\vec{I} = \int \vec{F} dt = \Delta \vec{p}$

Center of mass: $\vec{r}_{\text{cm}} = \frac{\sum m_i \vec{r}_i}{\sum m_i}$; $\vec{v}_{\text{cm}} = \frac{\sum m_i \vec{v}_i}{\sum m_i}$

Collisions: $\vec{p} = \text{const}$ and $E \neq \text{const}$ (inelastic) or $\vec{p} = \text{const}$ and $E = \text{const}$ (elastic)

Rotational motion: $\omega = 2\pi / T$; $\omega = d\theta / dt$; $\alpha = d\omega / dt$; $v_t = r\omega$; $a_t = r\alpha$; $a_c = a_r = v_t^2 / r = \omega^2 r$

$a_{\text{tot}}^2 = a_r^2 + a_t^2$; $v_{\text{cm}} = r\omega$ (rolling, no slipping) ; $a_{\text{cm}} = r\alpha$

$\omega = \omega_o + \alpha t$; $\theta_f = \theta_i + \omega_o t + \alpha t^2 / 2$; $\omega_f^2 = \omega_i^2 + 2\alpha(\theta_f - \theta_i)$

$I_{\text{point}} = MR^2$; $I_{\text{hoop}} = MR^2$; $I_{\text{disk}} = MR^2 / 2$; $I_{\text{sphere}} = 2MR^2 / 5$; $I_{\text{shell}} = 2MR^2 / 3$; $I_{\text{rod(center)}} = ML^2 / 12$

$I_{\text{rod(end)}} = ML^2 / 3$; $I = \sum m_i r_i^2$; $I = I_{\text{cm}} + Mh^2$; $\vec{\tau} = \vec{r} \times \vec{F}$; $\sum \tau = I\alpha$; $\vec{L} = \vec{r} \times \vec{p}$; $\vec{L} = I\vec{\omega}$

Energy: $K_{\text{rot}} = I\omega^2 / 2$; $K = K_{\text{rot}} + K_{\text{cm}}$; $\Delta K + \Delta U = 0$; $W = \tau \Delta \theta$; $P_{\text{inst}} = \tau \omega$

Fluid: $\rho = \frac{M}{V}$; $P = P_o + \rho g h$; $A_1 v_1 = A_2 v_2$; $P_1 + \rho g y_1 + \frac{1}{2} \rho v_1^2 = P_2 + \rho g y_2 + \frac{1}{2} \rho v_2^2$

Gravitation: $\vec{F}_g = -\frac{Gm_1 m_2}{r^2} \hat{r}_{12}$; $g(r) = GM / r^2$; $U = -Gm_1 m_2 / r$; $T^2 = \frac{4\pi^2}{GM} a^3$

Oscillatory motion: $= \frac{1}{2\pi} \sqrt{\frac{k}{M}}$; $\omega = \sqrt{\frac{k}{M}}$; $f = \frac{1}{2\pi} \sqrt{\frac{g}{L}}$; $\omega = \sqrt{\frac{g}{L}}$

The exam is closed book and closed notes.

Vectors: $A_x = A \cos\theta$; $A_y = A \sin\theta$; $A = \sqrt{A_x^2 + A_y^2}$ $\theta = \tan^{-1} \frac{A_y}{A_x}$; $\vec{A} = A_x \vec{i} + A_y \vec{j}$ $\vec{A} + \vec{B} = (A_x + B_x) \vec{i} + (A_y + B_y) \vec{j}$

$\vec{A} \cdot \vec{B} = A \cdot B \cos\theta = A_x B_x + A_y B_y$ $\vec{A} \times \vec{B} = AB \sin\theta = (A_x B_y - A_y B_x) \vec{k}$ One-dimen. motion: $x = v_{avr} t$ $x = \frac{v_i + v_f}{2} t$

$x = v_o t + \frac{1}{2} a t^2$ $x_f = x_i + \frac{v_f^2 - v_i^2}{2a}$ $v = v_o + at$; Free-fall: $y = v_o t - \frac{1}{2} g t^2$, $v = v_o - g t$,

$y_f = y_i + \frac{v_f^2 - v_i^2}{-2g}$; $y_{max} = \frac{v_i^2}{2g}$ $t_{tot} = \frac{2v_i}{g}$ $r = r_o + (v_{ox} t + \frac{1}{2} a_x t^2) \hat{i} + (v_{oy} t + \frac{1}{2} a_y t^2) \hat{j}$ $v = (v_{ox} + a_x t) \hat{i} + (v_{oy} + a_y t) \hat{j}$;

Projectile motion: $x = v_{ox} t$; $y = v_{oy} t - \frac{1}{2} g t^2$; $v_y = v_{oy} - g t$; $v_{ox} = v_o \cos\theta$; $v_{oy} = v_o \sin\theta$;

$y = \frac{v_y^2 - v_{oy}^2}{-2g}$ $t_{tot} = \frac{2v_{oy}}{g}$ $R = \frac{v_o^2 \sin 2\theta}{g}$; $y = (\tan\theta) \cdot x - \frac{g x^2}{2(v_o \cos\theta)^2}$ $F_{net} = ma$; $F_g = mg$, incline: $F_{gx} =$

$mg \sin\theta$, $F_{gy} = mg \cos\theta$, Friction: $f_{s,max} = \mu_s N$; $f_k = \mu_k N$; Circular motion: $a_c = \frac{v^2}{R}$; period $T = \frac{2\pi R}{v}$; $F_{net} = \frac{mv^2}{r}$;

Work: $W = F \cdot d \cdot \cos\theta$ $W_g = mg(y_o - y_f)$ $W_{spr} = \frac{1}{2} k(x_i^2 - x_f^2)$ $W_{tot} = K_f - K_i$ $W_{tot} = F_{net} \cdot d$ $K = \frac{1}{2} mv^2$

$P = \frac{dW}{dt}$ $P_{avg} = \frac{W}{\Delta t}$ $U_g = mgy$ $U_s = \frac{1}{2} kx^2$ $U_{gi} + U_{si} + K_i + W_{fr} = U_{gf} + U_{sf} + K_f$ $\Delta U + \Delta K = W_{nc}$ $p = mv$;

$\vec{F} \Delta t = m \vec{v}_f - m \vec{v}_i$ $m_1 v_{1i} + m_2 v_{2i} = m_1 v_{1f} + m_2 v_{2f}$; perf. inelastic: $m_1 v_{1i} + m_2 v_{2i} = (m_1 + m_2) V$

Rotational motion: 1 rev = 2π rad; $\omega = \omega_o + \alpha t$; $\theta = \omega_o t + \frac{1}{2} \alpha t^2$; $\theta = \frac{\omega^2 - \omega_o^2}{2\alpha}$ $s = \theta r$ $v = \omega r$; $a_t = \alpha r$

$\tau = r F \sin\phi$; $\tau_{net} = I \alpha$; work: $W = \tau \theta$; $W = \frac{1}{2} I \omega_f^2 - \frac{1}{2} I \omega_i^2$ $P_{avr} = \frac{W}{\Delta t}$ $I_{point\ mass} = mr^2$ $I_{disk,cyl} =$

$\frac{1}{2} mR^2$ $I_{hoop} = mR^2$ $I_{ball} = \frac{2}{5} mR^2$ $I_{shell} = \frac{2}{3} mR^2$ $I_{rod} = \frac{1}{12} mL^2$ $I_{rod(end)} = \frac{1}{3} mL^2$ $I = I_{com} + MD^2$

Rolling: $v_{com} = R\omega$ $K = \frac{1}{2} I \omega^2 + \frac{1}{2} m(v_{com})^2$ Angular momentum: $\vec{L}_{point\ mass} = m \vec{r} \times \vec{v}$ $L = mrv \sin\theta$; $\vec{L} = m(r_x v_y - r_y v_x) \vec{k}$ $L = I\omega$ $L_i = L_f$

Equilibrium: $\Sigma \vec{F} = 0$; $\Sigma \vec{\tau} = 0$ Gravitation: $G = 6.67 \times 10^{-11} \text{Nm}^2/\text{kg}^2$ $F = G \frac{m_1 \cdot m_2}{R^2}$ $g = G \frac{M_p}{R^2}$;

$U = -G \frac{M E m_o}{R}$; period $T = \frac{2\pi R}{v}$; $v_{esc} = \sqrt{\frac{2GM_p}{R}}$ $v_{sat} = \sqrt{\frac{GM_p}{R}}$; $T^2 = \frac{4\pi^2}{GM} R^3$;

$E_{sat} = -G \frac{M E m_o}{2R}$ Oscillations: $F = -kx$ $x = A \cos(\omega t + \theta)$ $v = -\omega A \sin(\omega t + \theta)$ $a = -\omega^2 x$ $\omega = 2\pi f = \frac{2\pi}{T}$

$\omega = \sqrt{\frac{k}{m}}$ period: $T_{spring} = 2\pi \sqrt{\frac{m}{k}}$; $f = \frac{1}{T}$ $T_{pend} = 2\pi \sqrt{\frac{L}{g}}$ $T_{phys.pend} = 2\pi \sqrt{\frac{I}{mgd}}$ $U_{spr} = \frac{1}{2} kx^2$ $E_{tot} = \frac{1}{2} kA^2$

$E_{tot} = \frac{1}{2} kx^2 + \frac{1}{2} mv^2$ $v_{max} = A\omega$ $a_{max} = A\omega^2$ $x_{cm} = \frac{m_1 x_1 + m_2 x_2}{m_1 + m_2}$ $y_{cm} = \frac{m_1 y_1 + m_2 y_2}{m_1 + m_2}$

NAME _____ SECT _____

Honors Code Pledge: As an NJIT student I _____, pledge to comply with the provisions of the NJIT Academic Honor Code. I assert that I have not violated the NJIT Academic Honor Code.

Answer each question on the Scantron card using #2 pencil. Also circle your answers on the question papers. SHOW HOW YOU GOT YOUR ANSWERS ON THE EXAM SHEETS. Use the back if necessary.

1. If $\mathbf{A} = 24\mathbf{i} - 32\mathbf{j}$ and $\mathbf{B} = 24\mathbf{i} + 10\mathbf{j}$, what is the direction of the vector $\mathbf{C} = \mathbf{A} - \mathbf{B}$?
 - a. -49°
 - b. -41°
 - c. **-90°**
 - d. $+49^\circ$
 - e. $+21^\circ$

2. A motorist drives south at 20 m/s for 3 min, then turns west and travels at 25 m/s for 2 min. What is the average velocity for this 5 min trip?
 - a. 12.2 m/s
 - b. **15.6 m/s**
 - c. 5.4 m/s
 - d. 22.0 m/s
 - e. 25 m/s

3. The position of a particle as it moves along the x axis is given by $x = 15e^{-2t}$ m, where t is in s. What is the acceleration of the particle at $t = 1.0$ s?
 - a. 22 m/s
 - b. 60 m/s
 - c. **8.1 m/s**
 - d. 15 m/s
 - e. 35 m/s

4. A ball is thrown horizontally from the top of a building 0.10 km high. The ball strikes the ground at a point 65 m horizontally away from and below the point of release. What is the initial speed of the ball?
 - a. 43 m/s
 - b. 47 m/s
 - c. 39 m/s
 - d. 36 m/s
 - e. **14 m/s**

5. A 1.5-kg mass has an acceleration of $(4.0\hat{i} - 3.0\hat{j}) \text{ m/s}^2$. Only two forces act on the mass. If one of the forces is $(2.0\hat{i} - 1.4\hat{j}) \text{ N}$, what is the magnitude of the other force?

- a. 4.1 N
- b. 6.1 N
- c. 5.1 N
- d. 7.1 N
- e. 2.4 N

6. If $F = 4.0 \text{ N}$ and $m = 2.0 \text{ kg}$, what is the magnitude a of the acceleration for the block shown below? The surface is frictionless.

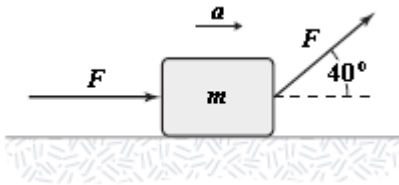

- a. 5.3 m/s^2
- b. 4.4 m/s^2
- c. **3.5 m/s^2**
- d. 6.2 m/s^2
- e. 8.4 m/s^2

7. A 4.0-kg block slides down a 35° incline at a constant speed. What is the coefficient of kinetic friction between the block and the surface of the incline?

- a. 0.20
- b. 0.33
- c. 0.46
- d. 0.53
- e. **0.70**

8. A 2.0-kg projectile moves from its initial position to a point that is displaced 20 m horizontally and 15 m above its initial position. How much work is done by the gravitational force on the projectile?

- a. +0.29 kJ
- b. **-0.29 kJ**
- c. +30 J
- d. -30 J
- e. -50 J

9. A moving particle is subject to conservative forces only. When its kinetic energy decreases by 10 J, what happens to its mechanical energy?

- a. It increases by 10 J.
- b. It decreases by 10 J.
- c. It increases, but not necessarily by 10 J.
- d. It decreases, but not necessarily by 10 J.
- e. **It remains the same.**

10. A 25-kg block on a horizontal surface is attached to a light spring (force constant = 8.0 kN/m). The block is pulled 10 cm to the right from its equilibrium position and released from rest. When the block has moved 2.0 cm toward its equilibrium position, its kinetic energy is 12 J. What is the change in mechanical energy caused by the frictional force on the block as it moves the 2.0 cm?

- a. -4.0 J
- b. -0.5 J
- c. **-2.4 J**
- d. -7.9 J
- e. -15 J

11. A 2.4-kg ball falling vertically hits the floor with a speed of 2.5 m/s and rebounds with a speed of 1.5 m/s. What is the magnitude of the impulse exerted on the ball by the floor?

- a. **9.6 N·s**
- b. 2.4 N·s
- c. 6.4 N·s
- d. 1.6 N·s
- e. 1.0 N·s

12. A 10-g bullet moving horizontally with a speed of 1.8 km/s strikes and passes through a 5.0-kg block initially at rest on a horizontal frictionless surface. The bullet emerges from the block with a speed of 1.0 km/s. What is the speed of the block immediately after the bullet emerges?

- a. 25 m/s
- b. **1.6 m/s**
- c. 5.3 m/s
- d. 9.4 m/s
- e. 125 m/s

13. A 2.0-kg object moving horizontally at 3.0 m/s strikes a 1.0-kg object initially at rest. Immediately after the collision, the 2.0-kg object has a velocity of 1.5 m/s directed 30° from its initial direction of motion. What is the y component of the velocity of the 1.0-kg object just after the collision?

- a. -3.7 m/s
- b. -3.4 m/s
- c. **-1.5 m/s**
- d. -2.4 m/s
- e. -4.1 m/s

14. A wheel rotating about a fixed axis has an angular position given by $\theta = 3.0 - 2.0t^3$, where θ is measured in radians and t in seconds. What is the angular acceleration of the wheel at $t = 2.0$ s?

- a. -1.0 rad/s²
- b. **-24 rad/s²**
- c. -2.0 rad/s²
- d. -4.0 rad/s²
- e. -3.5 rad/s²

15. A horizontal 98 N disk of radius 75 cm, initially at rest, rotates under a constant force of 50 N applied tangentially to the edge of the disk. The acceleration of the disk is closest to

- a. **13.3 rad/s²**
- b. 1.8 rad/s²
- c. 15.0 rad/s²
- d. 8.9 rad/s²
- e. 4.3 rad/s²

16. A uniform rod of mass $M=1.2$ kg and length 1.8 m is free to rotate on a frictionless pin passing through one end. The rod is released from rest in the horizontal position. What is its angular speed as it swings through the vertical position?

- a. 1.4 rad/s
- b. **4.0 rad/s**
- c. 9.9 rad/s
- d. 7.8 rad/s
- e. 16.8 rad/s

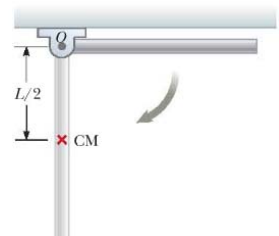

17. A solid cylinder (radius $R = 20\text{ cm}$, mass $M = 2.5\text{ kg}$) rolls without slipping down an 15° -incline as shown in the figure. If the incline is 1.2 m long and the cylinder starts from rest, what is the linear velocity of its center of mass at the bottom of the incline?

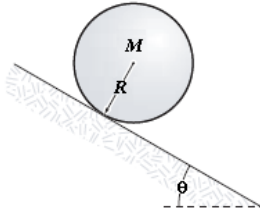

- a. 0.7 m/s
- b. 1.3 m/s
- c. **2.0 m/s**
- d. 3.5 m/s
- e. 4.4 m/s

18. A particle whose mass is 2 kg moves in the xy plane with a constant speed of 3 m/s along the direction $\hat{\mathbf{r}} = \hat{\mathbf{i}} + \hat{\mathbf{j}}$. What is its angular momentum (in $\text{kg}\cdot\text{m}^2/\text{s}$) relative to the origin?

- a. $0\hat{\mathbf{k}}$
- b. $6\sqrt{2}\hat{\mathbf{k}}$
- c. $-6\sqrt{2}\hat{\mathbf{k}}$
- d. $6\hat{\mathbf{k}}$
- e. $-6\hat{\mathbf{k}}$

19. A puck on a frictionless air hockey table has a mass of 0.5 kg and is attached to a cord passing through a hole in the surface as in the figure. The puck is revolving at a distance 1.2 m from the hole with an angular velocity of 1.0 rev/s . The angular momentum of the puck (in $\text{kg}\cdot\text{m}^2/\text{s}$) is

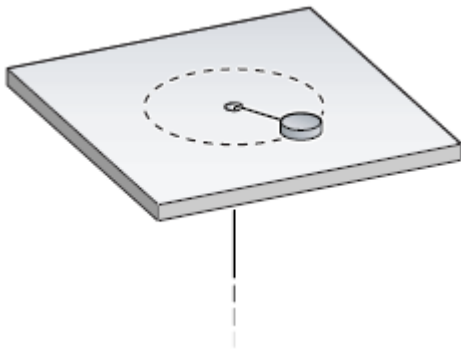

- a. 8.0
- b. 2.8
- c. 30.0
- d. **4.5**
- e. 7.5

20. A star rotates with a period of 20 days about its center. After the star undergoes a supernova explosion, the stellar core, which has a radius of 2×10^4 km, collapses into a neutron star of radius of 300 km. Find the period of rotation of the neutron star. Treat the star as a solid sphere.

- a. 4 s
- b. 6.5 min**
- c. 100 hrs
- d. 50 days
- e. 2 years

21. Calculate the magnitude of the net torque on the beam in the figure about an axis through zero, perpendicular to the page.

- a. 29.6 Nm**
- b. 13.7 Nm
- c. 43.3 Nm
- d. 57 Nm
- e. 78 NM

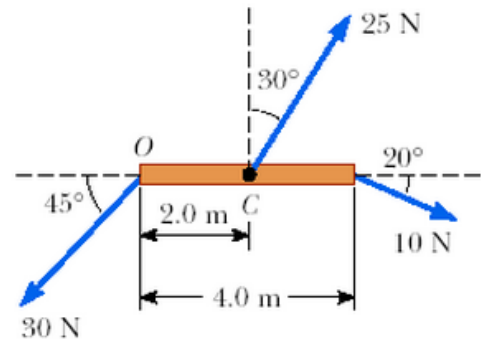

22. The figure shows a uniform, horizontal beam (length = 10 m) that is pivoted at the wall, with its far end supported by a cable that makes an angle of 51° with the horizontal. If a person (mass = 60 kg) stands 3.0 m from the pivot, what is the tension in the cable? Ignore the mass of the beam.

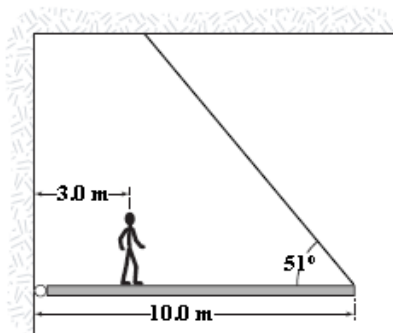

- a. 0.83 kN
- b. 1.30 kN
- c. 0.23 kN**
- d. 0.42 kN
- e. 3.0 kN

23. An object of unknown weight is suspended as shown. The tension in rope 1 is 25 N, and the tension in rope 2 is 31 N. What is the weight of the suspended object?

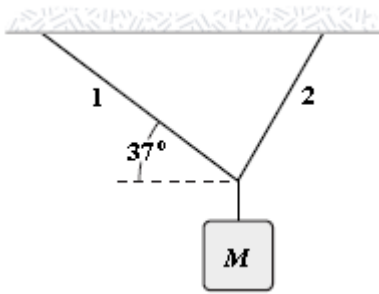

- a. 6 N
- b. 13 N
- c. 23 N
- d. 39 N**
- e. 56 N

24. The planet Venus requires 225 days to orbit the sun, which has a mass $M = 1.99 \times 10^{30}$ kg, in an almost circular trajectory. Calculate the radius of the orbit as it circles the sun.

- a. 6.2×10^7 m
- b. 5.0×10^{22} m
- c. 8.5×10^{10} m
- d. 1.1×10^{11} m**
- e. 3.7×10^{25} m

27 A body oscillates with simple harmonic motion with amplitude of 5 cm and the period of 0.3 s. Find the maximum acceleration of the object.

- a. 1.5 m/s^2
- b. 49 m/s^2
- c. 19 m/s^2
- d. 13 m/s^2
- e. 22 m/s^2