

Practice Problems, Physics 111 Common Exam 2, Fall 2024
Chapters: 4, 5, 6 and 7

1. A block is pushed across a horizontal surface by the force shown. If the coefficient of kinetic friction between the block and the surface is 0.30, $F = 20\text{ N}$, $\theta = 30^\circ$, and $M = 3.0\text{ kg}$, what is the magnitude of the acceleration of the block?

- A) 2.8 m/s^2
- B) 2.3 m/s^2
- C) **1.8 m/s^2**
- D) 3.8 m/s^2
- E) 5.4 m/s^2

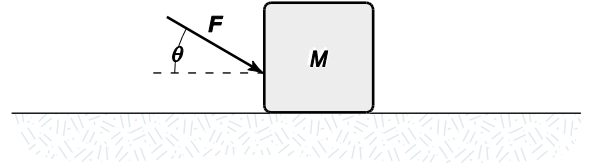

2. The system shown is on verge of starting moving up the incline. Each block weighs 20 N and an incline angle is 28° . The coefficient of static friction between the block M and the incline is closest to:

- A) 0.2
- B) 0.3
- C) 0.4
- D) 0.5
- E) **0.6**

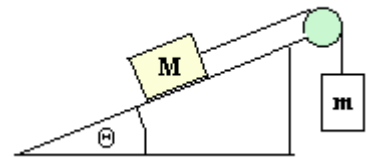

3. Traveling at a speed of 21 m/s, the driver of a car suddenly locks the wheels by slamming on the brakes. The coefficient of kinetic friction between the tires and the road is 0.72. How much time does it take for the car to come to stop?

- A) 1 sec
- B) 2 sec
- C) **3 sec**
- D) 4 sec
- E) 5 sec

4. A 1.0-kg block is pushed up a rough 22° inclined plane by a force of 7.0 N acting parallel to the incline. The acceleration of the block is 1.4 m/s^2 up the incline. Determine the magnitude of the force of friction acting on the block.

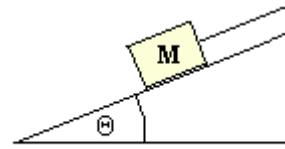

- a. **1.9 N**
- b. 2.2 N
- c. 1.3 N
- d. 1.6 N
- e. 3.3 N

5. If the resultant force acting on a 2.0-kg object is equal to $(3\hat{i} + 4\hat{j})$ N, what is the change in kinetic energy as the object moves from $(7\hat{i} - 8\hat{j})$ m to $(11\hat{i} - 5\hat{j})$ m?

- A) +36 J
- B) +28 J
- C) +32 J
- D) +24 J**
- E) +60 J

6. An all-terrain vehicle of 2000 kg mass moves up a 15.0° slope at a constant velocity of 6.00 m/s. The rate of change of gravitational potential energy with time is

- A) 5.25 kW.
- B) 24.8 kW.
- C) 30.4 kW.**
- D) 118 kW
- E) 439 kW.

7. A 10-kg object is dropped from rest. After falling a distance of 50 m, it has a speed of 26 m/s. How much work is done by the dissipative (air) resistive force on the object during this descent?

- A) -1.3 kJ
- B) -1.5 kJ**
- C) -1.8 kJ
- D) -2.0 kJ
- E) -2.3 kJ

8. A horizontal spring with a 10000 N/m spring constant is compressed 0.08 m, and a 12-kg block is placed against it. When the block is released, the block shoots forward along a horizontal surface that exerts 8 N friction force on the block. How far from the original position does the block travel before coming to a stop?

- A) 3.2 m
- B) 4.0 m**
- C) 6.4 m
- D) 7.0 m
- E) 8.0 m

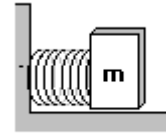

9. At what angle should a curve of radius 150 m be banked, so cars can travel safely at 25 m/s without relying on friction?

- A) $\Theta = 6.7^\circ$
- B) $\Theta = 9.5^\circ$
- C) $\Theta = 12.0^\circ$
- D) $\Theta = 18.1^\circ$
- E) $\Theta = 23.0^\circ$**

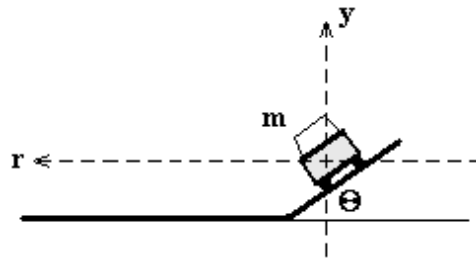

10. A certain pendulum consists of a 2-kg mass swinging at the end of a string (length = 2.0 m). At the lowest point in the swing the tension in the string is equal to 30 N. What angle will the string make with a vertical when the mass reaches its maximum height?

- A) 42.7°**
- B) 28.4°
- C) 12.5°
- D) 56°
- E) 8.8°

11. A roller coaster track has a hill with a circular curve of radius $r = 15$ m. What is the normal force on the 60-kg passenger when the roller coaster passes the hill at 8 m/s?

- A) 112 N
- B) 186 N
- C) 332 N**
- D) 588 N
- E) 844 N

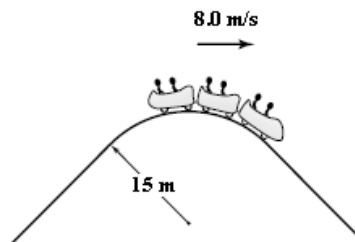

12. A 2.0-kg block slides down a frictionless incline from point A to point B. A force (magnitude $P = 3.0$ N) acts on the block between A and B, as shown. Points A and B are 2.0 m apart. If the kinetic energy of the block at A is 10 J, what is the kinetic energy of the block at B?

- A) 27 J
- B) 20 J
- C) **24 J**
- D) 17 J
- E) 37 J

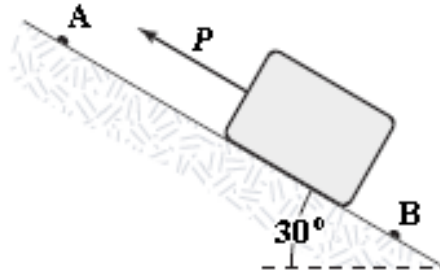

13. A 0.04-kg ball is thrown from the top of a 30-m tall building (point A) at an unknown angle above the horizontal. As shown in the figure, the ball attains a maximum height of 10 m above the top of the building before striking the ground at point B. If air resistance is negligible, what is the value of the kinetic energy of the ball at B minus the kinetic energy of the ball at A ($K_B - K_A$)?

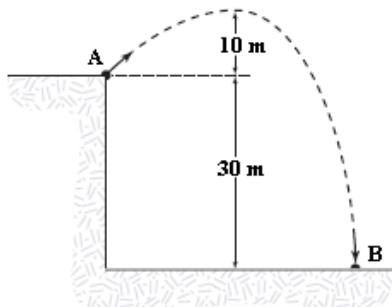

- A) **12 J**
- B) -12 J
- C) 20 J
- D) -20 J
- E) 32 J

14. A 2.0-kg block sliding on a horizontal frictionless surface is attached to one end of a horizontal spring ($k = 200 \text{ N/m}$) which has its other end fixed. If the block has a speed of 4.0 m/s as it passes through the equilibrium position, what is its speed when it is 20 cm from the equilibrium position?
- 2.6 m/s
 - 3.1 m/s
 - 3.5 m/s**
 - 1.9 m/s
 - 2.3 m/s

15. The block shown is released from rest when the spring is stretched a distance d . If $k = 50 \text{ N/m}$, $m = 0.50 \text{ kg}$, $d = 10 \text{ cm}$, and the coefficient of kinetic friction between the block and the horizontal surface is equal to 0.25, determine the speed of the block when it first passes through the position for which the spring is unstretched.

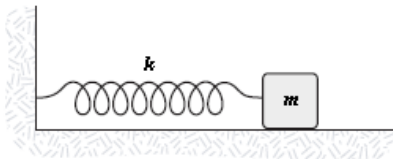

- 92 cm/s
 - 61 cm/s
 - 71 cm/s**
 - 82 cm/s
 - 53 cm/s
16. Find the direction of the net force of three forces shown in the figure below.

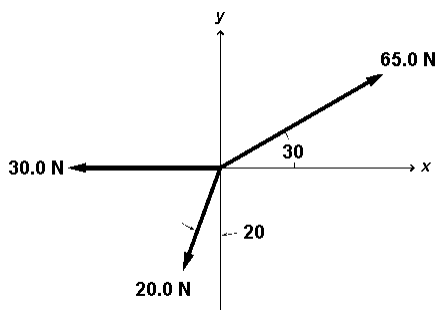

- 35°**
- 45°
- 65°
- 55°
- 85°

17. A 3.00-kg mass undergoes an acceleration given by $\mathbf{a} = (2\mathbf{i}+5\mathbf{j}) \text{ m/s}^2$. The magnitude of the net force is

- A) 2.0 N
- B) 4.0 N
- C) 6.0 N
- D) 12.0 N
- E) **16.0 N**

18. A 20 N force \mathbf{F} , parallel to the incline is required to push a certain crate at acceleration of 1.6 m/s^2 up an incline that is $\Phi = 28^\circ$ above the horizontal. What is the mass of the crate?

- A) 2.31kg
- B) 3.49kg
- C) **3.22kg**
- D) 5.84kg
- E) 6.04 kg

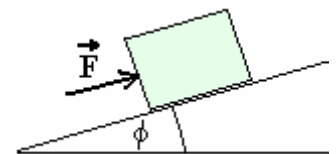

19. A wooden block with mass 1.50 kg is placed against a compressed spring at the bottom of an incline of slope 30.0° (point A). When the spring is released, it projects the block up the incline. At point B, a distance of 6.00 m up the incline from A, the block is moving up the incline at 7.00 m/s and is no longer in contact with the spring. The coefficient of kinetic friction between the block and the incline is $\mu_k = 0.50$. The mass of the spring is negligible. Calculate the amount of potential energy that was initially stored in the spring

- A) 20 J
- B) 40 J
- C) 98 J
- D) 135 J
- E) **119 J**

20. If $F = 5.0 \text{ N}$, what is the magnitude of the force exerted by block 2 on block 1?

- A) **17 N**
- B) 19 N
- C) 21 N
- D) 23 N
- E) 5.0 N

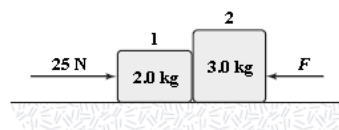

21. A system of two paint buckets connected by a lightweight rope is released from rest with the 12.0 kg bucket 2.00 m above the floor. Use the principle of conservation of energy to find the speed with which this bucket strikes the floor. Ignore friction and the mass of the pulley.

- A) 2.6 m/s
- B) 3.1 m/s
- C) **4.4 m/s**
- D) 1.9 m/s
- E) 2.3 m/s

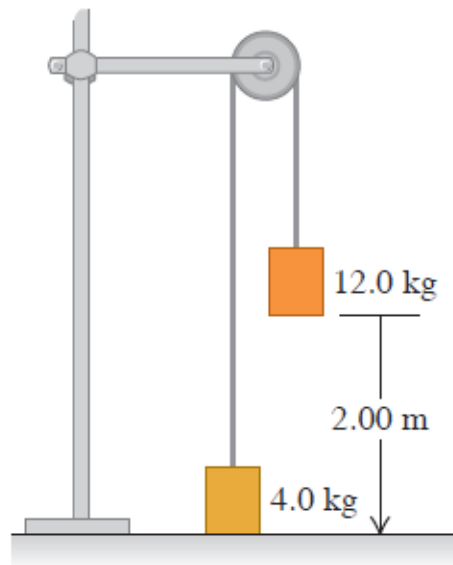

22. A force parallel to the x-axis acts on a particle moving along the x-axis. This force produces potential energy $U(x)$ given by $U(x) = \alpha x^4$, where $\alpha = 0.630 \text{ J/m}^4$. What is the force (magnitude and direction) when the particle is at $x = -0.800 \text{ m}$?

- A) **1.29 N**
- B) 1.9 N
- C) 2.1 N
- D) 23 N
- E) 5.0 N